

CITY OF CHELLEY  
COUNCIL MEETING  
MINUTES

AUGUST 10, 2010

PRESENT: Mayor Eric Christensen  
Council Members: John Lent (absent), Charlotte Fredrickson, Earl Beattie, and Kurt Russell  
Police Chief: Alan Dial  
Public Wks Dir: Chuck Lloyd  
Recreation Dir.: Dawn Lloyd  
City Clerk: Sandy Gaydusek  
City Attorney: B.J. Driscoll

PLEDGE OF ALLEGIANCE: Dawn Lloyd

PRAYER: BJ Driscoll

Charlotte moved, Kurt seconded to approve the following consent agenda:

Minutes of July 27, 2010 Council Meeting

Special Minutes of August 5, 2010

Building Permits:

Mary Fleming - move on home  
Janeal Swanson - re-roof

A roll call vote was called for: Earl – aye, Charlotte – aye, and Kurt – aye. Approved three in favor, one absent.

Mayor Christensen turned the time over to BJ to open the bids that were submitted for the city owned property between 375 W. Center and 405 W. Center. BJ said he received two bids for the property. Sandy said the publication was for sealed bids to be accepted until 5:00 p.m., August 10, 2010. BJ said there was an error on the legal description that was published. He said two tracts of land were published for sale, but the city only has ownership of one that lies between 375 and 405 W. Center Street. He said the extra parcel of land lies between Lyn Beck and Frank Carter that is further to the west than the property being auctioned. BJ said he did not feel this error should have a major impact on the sale of this property since the physical address and legal description were given in the publication. Pat Kearney said he and his neighbor, David Picanco were going to bid together on the property, but it did not work out correctly. He said he is concerned about the placement and radius of the piece of property being sold. He said he and Mr. Picanco can work out an easement between the two of them. BJ said this property is not a public right-of-way, easement or alley. Mr. Kearney said he would like the radius to be followed as a straight line across the property. He said he is concerned about the existing improvements, and he wants Mr. Picanco to honor the radius line as the property line. BJ said he was not sure what Mr. Kearney was asking for. Mr. Kearney said he would withdraw his bid if he could be guaranteed that the property line would follow this existing radius. In other words if the legal description for the property being sold runs past the radius line and onto the property Mr. Kearney believes to be his, he would like the property Quit Claimed to him to the radius line. BJ said this would be between the two property owners and not up to the city. He said once the property is sold, the city no longer has any interest in the property. David Picanco said he was

willing to work with Mr. Kearney on this matter. Mr. Pat Kearney said he would like withdraw his bid. BJ gave Mr. Kearney his unopened bid and opened the remaining bid received. This bid was submitted by David and Leah Picanco in the amount of \$105 for the described parcel of property between 375 and 405 West Center Street. Earl moved, Charlotte seconded to accept the bid of \$105 from David and Leah Picanco for the city owned property between 375 and 405 West Center Street and described as Tract 2 in the Legal Description. Approved three in favor, one absent.

Sandy said the survey was complete on the alley running between West Center and West Maple Street. She said there is an encroachment of a concrete building on the northern end of the alley. The building is on property owned by Alva Harris, however he intends to demolish and remove the building. Earl said he and Chuck looked at the alley and there is approximately six feet of grass from the Wright property that lies on the alley. He said he and John met with Doris and Jack Jones concerning this alley, and they intend to meet with the Wrights when they return from vacation. Earl said he felt the alley should be opened up. Mrs. Jones asked if the alley could be vacated or sold. She asked why it is so important to open this up as an alley now. Earl said people need to be able to access the back of their property from this alley. Mrs. Jones said people have been using this alley on the northern end for the past thirty years. She said everyone should not be held responsible for the sprinkler system that the Cedar Apartments installed. Bryon Moore said he would be willing to live with a gate or a movable fence on the alleyway. He felt that he did not want to lose his rights to the alley way even though he has "put up" with the blocked access on the southern end of the alley for the past years. Mrs. Jones said she is concerned about the traffic that would still be using the alley even with a gate installed. Mrs. Moore said she has a concern about installing a gate on the alley because it may create the situation that other people might want gates installed in their alleys. Sandy said she received a letter and pictures regarding this matter from Monica Wright that she has included in the Governing Boards council binders with the exception of the pictures that were emailed to each of them. Sandy explained the procedure to vacate a portion of an alley, and stated once the property is vacated it reverts to the property owns on each side. Earl said he is concerned that if a portion of the alley is vacated, others may want the entire alley vacated. Earl moved, Kurt seconded to table this issue until the next meeting. Approved three in favor, one absent.

Chuck said he met with Dave Noel and Kelly Bond regarding the design for the new well. He said both parties recommended the city drill a test well. Chuck said since it is unknown what the ground will be like when it is drilled, a test well may save the city money in the end. He said the city previously discussed a test well and it was thought to cost about \$20,000, however we have an estimate of \$7235. Chuck said the City of Rigby did not have a test well drilled and could have saved \$80,000 if they would have, so they could have known what size of pipe was needed. Chuck said a test well would allow the city to know if there is gravel, lava rock or what that will be drilled through. Mayor Christensen asked what will happen if a dry hole is hit. Chuck said he did not know. Chuck said Dave would like to get the bid specifications out for the well drilling, and he needs to know about a test well. Charlotte moved, Earl seconded to approve the drilling

of a test well contingent upon the cost being included in the \$450,000 that was budgeted for the well. Approved three in favor, one absent.

Charlotte moved, Kurt seconded to approve the following business licenses for 2010:

Cloth Doll Creations - General Business License

Jordan Cook/Corn - Itinerant Business License

Approved three in favor, one absent.

Sandy presented the street light specifications she received from the city engineers. She said since Rocky Mountain Power has changed their program, the city must provide its own maintenance and installation on the street lights, or pay approximately \$30 per light per month for Rocky Mountain Power to install and maintain. Therefore, developers must install the street lights in their subdivisions, so specifications are needed. Sandy said these specifications are very basic and would allow the city street light to be uniform. Earl moved, Charlotte seconded to adopt the street light specifications dated 7/29/10 as drafted by the city engineers. ( A copy is attached) Approved three in favor, one absent.

Sandy presented comment sheets she received from Bingham County regarding a PUD called Hidden Ridges east of the city. Council had no comments or concerns. Sandy presented comment sheets she received from Bingham County regarding a Special Use Permit for Western Energy involving the setbacks for wind turbines. The Council had no comments or concerns.

Sandy discussed the proposed budget with the Mayor and Council. She said since the work meeting held on August 5, 2010, she has figured the budget based on the direction the council gave her. Sandy said the proposed budget will include the following: 3% property tax levy increase, \$2.15 per month increase for sewer rates, \$.10 per month increase for sanitation rates, increase truck usage from \$30 to \$50, implement a dog turn in fee of \$25 and a special circumstance water turn off of \$100. The proposed expenditures include the hiring of an employee for public works to fill the vacancy left by Chuck's promotion, two mobile cameras, two tasers, a phone system, computer, flat bed truck, bobcat, pool bathroom remodel and two new picnic tables. There will be a wage freeze for both merit and cost of living raises, and the city will continue to have Blue Shield for medical insurance and increase the deductible to \$3000. Sandy said she will continue pulling the budget together for consideration of a tentative adoption.

The Mayor and Council discussed the Urban Renewal Area and the funding it receives each year. It was discussed whether the funds could be used in the General Fund. Sandy said the funds can not be put on hold for a year, however the street may be able to receive some funding assistance from Urban Renewal Funds on repaving projects within the URD boundary.

Earl moved, Kurt seconded to call for a special meeting on August 16, 2010 at 7:30 p.m. to consider adoption of the tentative budget for publication of the Budget Hearing on September 7, 2010. Approved three in favor, one absent.

Sandy said Alva Harris spoke with her about the condition of his property on North Byron. He said he is trying to get the property cleaned up, but it is going to take some time. Mr. Moore who lives next door to the Harris property said Mr. Harris works on his clean up efforts a few days a week, and at that rate it is going to take a long time to clear the property. Earl felt the city needs to follow through with a citation. Charlotte said he is making an effort to clean up the property. Mr. Moore said there are piles of feces that are in the buildings. Sandy said there have been a few citations issued for property appearance that we have went to court on. The council discussed different options for handling the compliance of this property and determined Mr. Harris should be cited. In the future the council may review the procedure for non-compliance with this ordinance.

Dawn said a patron has offered to donate \$350,000 to the city for the construction of a spray park. Dawn said she is working on the expenses associated with the proposed park, and would like to access the existing pool.

Dawn said she is working on obtaining quotes to resurface the tennis courts that are in very poor condition.

Chuck said the sprinkler system along the walk path is almost finished. The next step is for the contractor to hydro seed.

Alan said Jed <sup>is</sup> ~~will~~ be leaving August 20, 2010. He said Kent Swanson and Stan Peterson will be the department supervisors. Alan said Stan has been a supervisor for the past year and never received the stipend. He said Kent will be replacing Jed and the city will need to pay him the stipend and he would like to request that Stan receive the stipend too. Charlotte moved, Earl seconded to approve stipend pay for Stan Peterson as a second police department supervisor beginning October 1, 2010. Approved three in favor, one absent.

Alan said the School District has always used the SRO to provide their teachers fingerprinting at no expense. He said now that there will be no SRO the school still wants the fingerprints done at no cost. The Council determined that the police department will provide fingerprinting at no cost to the teachers on one designated day that everyone can be done at once. Earl moved, Charlotte seconded to waive the fingerprint fees for one designated day for school fingerprinting. Approved three in favor, one absent.

Kurt said he received an invitation for the ribbon cutting ceremony for the new Riverview Grade School next Tuesday. He said he will be attending this event.

Earl said the American Legion had a cookout to honor the National Guard that was leaving or returning from service. He commented that this was a very nice event to have.

Mayor Christensen said on July 31, 2010 he attended a POW/MIA Motorcycle Rally/Parade in Pocatello. He said he rode in the parade, and this was a very well attended event.

Adjourned: 9:55 p.m.

ATTEST Sandy English APPROVE: Eric R. Christensen

**LEGEND**

- ① #4 VERTICAL REBAR.
- ② 6" LAP.
- ③ ANCHOR BOLT SIZE AND LOCATIONS PER MANUFACTURER'S SPECIFICATIONS.
- ④ 4" TO 6" STUBS.
- ⑤ INSULATED DUSHING REQUIRED WHEN CONDUIT IS USED. PER MANUFACTURER'S SPECIFICATIONS.
- ⑥ PER MANUFACTURER'S SPECIFICATIONS.
- ⑦ SIDEWALK LINE OR GRADE LINE.
- ⑧ J-BOX.
- ⑨ 1" MINIMUM DIAMETER.
- ⑩ (4) ANCHOR BOLTS WITH DOUBLE NUTS FOR PLUMBING POLE, GALVANIZED WITH (5) GALVANIZED NUTS AND (2) GALVANIZED WASHERS PER BOLT.
- ⑪ 4-#4 REBAR HOOPS.
- ⑫ C-3000 CONCRETE AS PER SECTION 700 ISPMWC.
- ⑬ SEE STANDARD SPECIFICATIONS FOR REQUIRED FIXTURES.
- ⑭ GENERAL ELECTRIC ALUMINUM SEALLESS #1/4" NO. 000035 OR UNION METAL ELEM. 703 OR APPROVED EQUAL.
- ⑮ FUSE LOCATION.
- ⑯ WATER-TIGHT HANDHOLE.
- ⑰ BACKFILL TO BE COMPACTED TO 95%.

**NOTE:**

- ① SEE ISPMWC FOR EXCAVATION, BACKFILLING AND CONSTRUCTION OF POLE FOUNDATION, WIRING AND ACCEPTANCE OR REJECTION OF THE WORK.
- ② GROUND POLE TO THE SERVICE POINT VIA #6 AWG BARE WIRE PER NATIONAL ELECTRICAL CODE.
- ③ #10 AWG WIRE FROM LUMINAIRE TO FUSE.
- ④ FOR GROUNDING DETAILS SEE SD-11021.

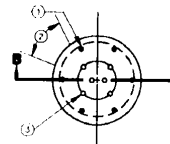

POLE FOUNDATION SCHEDULE					
HOOPS*		VERTICAL REBARS*		C.Y. CONC.	
QTY	SIZE	QTY	SIZE	QTY	FND.
4	#4	4	#4	4	

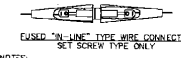
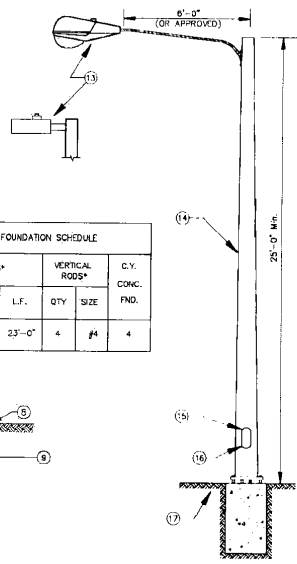
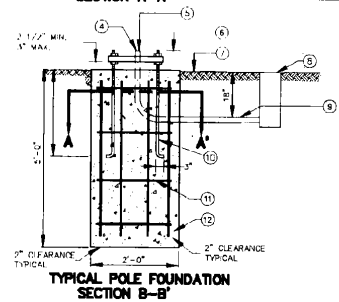

EUSED "IN-LINE" TYPE WIRE CONNECTOR  
SET SCREW TYPE ONLY

NOTES:  
(1) THE CONTRACTOR SHALL VERIFY LINE VOLTAGE PRIOR TO CONNECTING WIRE CONNECTORS.  
(2) CONTRACTOR SHALL CONNECT CONDUCTOR FROM THE WIRE CONNECTOR TO NEW LUMINAIRE WITH A NO. 10 AWG. TYPE THW, 600V INSULATED WIRE.

Install Fuse:  
Fast Acting-100K RMS Amps-600VAC  
SEC Model 1791-DF or SEC Model 1791-SF  
(or approved Equivalent)

Install Fused Junction Box  
(Approved Underground enclosure)  
To be set within 3 feet of Power Company J-Box or Transformer.

Install Fuse:  
Fast Acting-100K RMS Amps-600VAC  
S.L.C. Model 1791-DF or SEC Model 1791-SF  
(or approved Equivalent)

NEC Code Approved Connector

Hand Hole

NEC Code Approved Grounding Connector

1/2" x 6" P.V.C. Conduit  
Sleeve Fit Top 2" With Silicone Grease

NOTE:  
Additional J-Box (Pull Box) is Required when the Distance Between the Street Light and Fused Junction Box is 10 Feet or Greater.

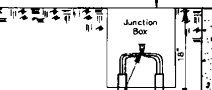
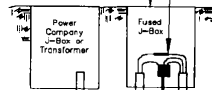

Ground Rod (Per NEC Article 250-0 Grounding Bonding Per NEC Article 250-5 Service)

NEC Code Approved Grounding Connector

Photo Cell (Tight Lock Type) Mark P.E. Control & Lamps with installation date

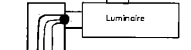

#10 Min. Wires from Fuse Connector to Fixture.

#8 Min. Wires from Power Source to Fuse Connector.

Height 4" to 6"

NOTE:  
1. For Concrete Base Details See ISPMWC Standard Drawing SD-1109  
2. Ground Rod May Be Placed in Lieu of Connection to Rebar Cage.

**FORSGREN**  
Associates, Inc.

CITY OF SHELLEY  
LIGHT POLE STANDARD DETAIL

PROJECT NUMBER	
PROJECT DRAWER	
D. NOEL	
DATE	7-28-10

<u>DATE</u>	<u>JULY CLAIMS</u>	<u>AMOUNT</u>	<u>CHECK #</u>
6-Jul-10	Comdata	448.36	34106
6-Jul-10	Glock Professional	150.00	34107
<b>14-Jul-10</b>	<b>Leroy and Barbara Scott</b>	<b>2,643.89</b>	<b>34108</b>
16-Jul-10	AAA Giles Cleaning and Restoration	675.00	34109
16-Jul-10	All American Sports	192.48	34110
16-Jul-10	American Linen	657.59	34111
16-Jul-10	Angelica Saldana	25.00	34112
16-Jul-10	BMC West Shelley	289.08	34113
16-Jul-10	Broulim's	191.87	34114
16-Jul-10	Brownells Inc	346.61	34115
16-Jul-10	Burns Concrete Inc	108.51	34116
16-Jul-10	Business Phone Specialists Inc	66.50	34117
16-Jul-10	Central Transfer Station	3.10	34118
<b>16-Jul-10</b>	<b>DBS Inc</b>	<b>2,738.76</b>	<b>34119</b>
16-Jul-10	Eagle Rock Nursery	87.05	34120
<b>16-Jul-10</b>	<b>Eagle Rock Sanitation</b>	<b>4,495.24</b>	<b>34121</b>
16-Jul-10	Electrical Wholesale Supply Co Inc	55.54	34122
16-Jul-10	Ferguson Enterprises Inc	84.36	34123
<b>16-Jul-10</b>	<b>Forsgren Associates/P.A.</b>	<b>4,354.45</b>	<b>34124</b>
16-Jul-10	H-K Contractors	597.68	34125
16-Jul-10	Hammon Teton Delivery	54.00	34126
16-Jul-10	HD Supply Waterworks LTD	277.50	34127
16-Jul-10	IAS-Envirochem	48.00	34128
<b>16-Jul-10</b>	<b>IBM Corporation</b>	<b>1,224.00</b>	<b>34129</b>
16-Jul-10	Idaho Business Systems	32.00	34130
16-Jul-10	Idaho Dept of Employment	586.40	34131
16-Jul-10	Idaho Rural water Association	440.00	34132
16-Jul-10	Industrial Hose and Fittings	129.41	34133
16-Jul-10	Intrat'l Inst. Of Municipal Clerks	125.00	34134
16-Jul-10	Lexisnexis Matthew Bender	56.71	34135
16-Jul-10	Petty Cash	62.39	34136
16-Jul-10	Pro Prower	352.14	34137
16-Jul-10	Qwest	46.55	34138
16-Jul-10	R&S Distributing	64.87	34139
<b>16-Jul-10</b>	<b>Rocky Mountain Power</b>	<b>10,819.32</b>	<b>34140</b>
<b>16-Jul-10</b>	<b>Sams Club</b>	<b>1,432.40</b>	<b>34141</b>
16-Jul-10	Shelley Pioneer	577.29	34142
<b>16-Jul-10</b>	<b>Smith Driscoll &amp; Associates PLLC</b>	<b>1,681.05</b>	<b>34143</b>
<b>16-Jul-10</b>	<b>State Insurance Fund</b>	<b>3,768.00</b>	<b>34144</b>
16-Jul-10	Town and Country Gardens	89.64	34145
16-Jul-10	United States Welding Inc	81.20	34146
16-Jul-10	2M Company Inc	437.53	34147
29-Jul-10	A & B Transmission & Service CTR	247.06	34148
29-Jul-10	Advanced Diagnostics Inc	180.00	34149
29-Jul-10	Airgas Intermountain Inc	15.65	34150
29-Jul-10	All American Sports	350.00	34151
29-Jul-10	Associated Business Forms & Systems	523.04	34152
29-Jul-10	Bethany Searle	80.00	34153
29-Jul-10	Void	-	34154
29-Jul-10	Cable One	164.95	34155
29-Jul-10	Cal Ranch	42.91	34156
29-Jul-10	Carolee Carlson	25.00	34157
<b>29-Jul-10</b>	<b>Cate-Idaho Equipment Co</b>	<b>1,026.00</b>	<b>34158</b>
29-Jul-10	Christine Wright	18.33	34159
<b>29-Jul-10</b>	<b>Circular Butte Landfill</b>	<b>6,078.84</b>	<b>34160</b>
<b>29-Jul-10</b>	<b>Columbia Paint Co</b>	<b>1,003.87</b>	<b>34161</b>
<b>29-Jul-10</b>	<b>Davies Aqua Chem Supply Co</b>	<b>3,476.58</b>	<b>34162</b>
<b>29-Jul-10</b>	<b>Electrical Equipment Co Inc</b>	<b>9,003.84</b>	<b>34163</b>
29-Jul-10	Exxonmobil Fleet/GECC	162.08	34164
29-Jul-10	Falls Plumbing Supply Co	84.50	34165
29-Jul-10	Fastenal	443.57	34166
<b>29-Jul-10</b>	<b>First Responders</b>	<b>1,123.45</b>	<b>34167</b>
29-Jul-10	H-K Contractors	543.46	34168
29-Jul-10	HD Fowler Company	32.86	34169
29-Jul-10	HD Supply Waterworks LTD	117.44	34170
29-Jul-10	Honnen Equipment Co of Utah/Idaho Inc	764.00	34171
<b>29-Jul-10</b>	<b>Intermountain Gas Co.</b>	<b>1,948.39</b>	<b>34172</b>

29-Jul-10	Jakes Mountain View Sales and Service	238.86	34173
29-Jul-10	Jeneal Wattenbarger	65.08	34174
29-Jul-10	Kings No. 21	49.98	34175
29-Jul-10	Kirkham Auto Parts Service Co. #8	219.59	34176
<b>29-Jul-10</b>	<b>Metroquip Inc</b>	<b>1,119.56</b>	<b>34177</b>
29-Jul-10	Mountain Valley Plumbing	85.00	34178
29-Jul-10	OK Trailer Sales	44.01	34179
29-Jul-10	Oldcastle Precast Inc	75.00	34180
<b>29-Jul-10</b>	<b>Phillips 66 Co</b>	<b>1,285.63</b>	<b>34181</b>
29-Jul-10	Pro Prower	28.99	34182
29-Jul-10	Qwest	475.32	34183
29-Jul-10	R&S Distributing	59.99	34184
29-Jul-10	Russ's Overhead Doors	444.76	34185
29-Jul-10	Shelley Quick Lube and Auto Center	585.46	34186
29-Jul-10	Stephenson Computer Consulting	37.50	34187
29-Jul-10	Town and Country Gardens	52.98	34188
29-Jul-10	U.S. Post Office	361.20	34189
<b>29-Jul-10</b>	<b>Wells Fargo Securities LLC</b>	<b>78,844.99</b>	<b>34190</b>
29-Jul-10	2M Company Inc	1,119.39	34191
<b>9-Jul-10</b>	<b>City of Shelley Payroll</b>	<b>53,545.44</b>	
<b>23-Jul-10</b>	<b>City of Shelley Payroll</b>	<b>52,518.10</b>	
	<b>Total</b>	<b>259,309.12</b>	